

MIG 160GDM/180GDM

WELDING MACHINE

***USER MANUAL***





## Preface

This manual includes hardware description and operation introduction of the equipments. For your and other people's safety, please read the manual carefully.

### Pay attention

Pay attention to the words after the signs below.

Sign	Description
 DANGER	The words after this sign means there is great potential danger, which may cause major accident, damage or even death, if it is not followed.
 WARNING	The words after this sign means there is some potential danger, which may cause hurt or property lose, if it is not followed.
 ATTENTION	The words after this sign means there is potential risk, which may cause equipment fault or break, if it is not followed.

### Version

Version YF-TAE-0059, A0, Released at 30th, 03, 2016.

The contents of this manual are updated irregularity for updating of product. The manual is only used as operation guide, except for other promises. No warranties of any kind, either express or implied are made in relation to the description, information or suggestion or any other contents of the manual.

# Content









1 Safety warning.....	3
2 Product.....	7
2.1 General.....	7
2.2 Technical data.....	8
3 Installation.....	10
4 Operation.....	13
4.1 Front panel layout.....	13
4.2 Operation instruction.....	13
4.3 Welding environment and safety.....	16
4.4 Welding problems and resolution.....	17
5 Daily maintenance and checking.....	18
6 Trouble shooting and fault finding.....	21
Appendix I Welding parameter list.....	22
Appendix II Circuit diagram.....	23

# 1 Safety warning

The safety notes listed in this manual is to ensure correct use of the machine and to keep you and other people from being hurt.

The design and manufacture of welding machine considers safety. Please refer to the safety warning listed in the manual to avoid accidents.

Different damage would be caused by wrong operation of the equipment as follows. Please read the user manual carefully to reduce such damage.

Sign	Description
	<ul style="list-style-type: none"> <li>✧ Any contact of electric parts may cause fatal electric shock or burnt.</li> </ul>
	<ul style="list-style-type: none"> <li>✧ Gas and fumes are harmful to health.</li> <li>✧ Operation in narrow space may cause choke .</li> </ul>
	<ul style="list-style-type: none"> <li>✧ Spark and hot workpiece after welding may cause fire.</li> <li>✧ Bad connected cable may cause fire.</li> <li>✧ Uncompleted connection of workpiece side circuit may cause fire.</li> <li>✧ Never weld on the case of tinder stuff, or it may cause explode.</li> <li>✧ Never weld airtight containers such as slot, pipe etc., or it may break.</li> </ul>
	<ul style="list-style-type: none"> <li>✧ Arc ray may cause eye inflammation or skin burnt.</li> <li>✧ Spark and residue will burn your eyes and skin.</li> </ul>
	<ul style="list-style-type: none"> <li>✧ Toppling over of the gas cylinder will cause body hurt.</li> <li>✧ Wrong use of the gas cylinder will lead to high-pressure gas eruption and cause human hurt.</li> </ul>
	<ul style="list-style-type: none"> <li>✧ Never let fingers, hair, clothes or etc. near the moving parts such as the fan.</li> </ul>
	<ul style="list-style-type: none"> <li>✧ The wire shoot out of the torch may stab eyes, face and other naked parts.</li> </ul>
	<ul style="list-style-type: none"> <li>✧ Never stand in front of the swang equipment or under it, or it may fail and cause injury.</li> </ul>

 **DANGER** Please follow the rules below to avoid heavy accidents.

- Never use the equipment to do other things but welding.
- Follow related regulations for the construction of the input-driven power source, choice of place, usage of high-pressure gas, storage, configuration, safe-keeping of workpiece after welding and disposal of waste, etc.
- Nonessentials do not enter the welding area.
- People using heart pacemaker is not allowed to get close to the welding machine or area without doctor's permission. The magnetism created by energizing the welding machine can have a bad effect to the pacemaker.
- Install, operation, check and maintain the equipment by profession personnel.
- Understanding the contents of the user manual for safety.

 **DANGER** Please follow the rules below to avoid electric shock.

- Keep away from any electric parts.
- Earth the machine and workpiece by professional personnel.
- Cut off the power before installation or checking, and restart 5 minutes later. The capacitance is chargeable device. Please ensure it has no voltage before start again even if the power source is cut off.
- Do not use wire with inadequate section surface or damage insulation sleeve or even exposed conductor.
- Do ensure well isolation of wire connection.
- Never use the device when the enclosure is removed.
- Never use broken or wet insulation gloves.
- Use firenet when work at high position.
- Check and maintain regularly, don't use it until the broken parts are fixed well.
- Turn off the power when not in used.
- Follow the national or local related standard and regulations when using the AC welding machine at narrow or high position.

 **DANGER** Please follow the below notes to avoid fire and explode, etc.

- No combustible in welding area.
- Keep off combustible when welding.
- Keep hot workpiece after welding away from flammable gas.
- Do move away the combustible around when weld the dooryard, ground and wall,.
- The wire connection of base metal should be as close to the welding place as possible.
- Never weld those facilities with gas pipe or airtight slot.
- Put fire extinguisher around the welding area to prevent fire.

 **WARNING** The gas and fumes are harmful to health, please wear protective device according to regulations.

- Wear exhaust equipment and breathe preventive facilities to prevent gas poisoning or choke.
- Use suggested part exhaust equipment and breathe preventive facilities to prevent hurt or poisoning by gas and other powder, please.
- To prevent oxygen-deficiency, air out the gas-filled room which is full of CO<sub>2</sub> and argon on

- the bottom, When operating on trunks, boilers, cabins, etc.
- Please accept the supervisor's inspection when operating in narrow space. Air the room and wear breathe preventive facilities.
  - Never operate in degrease, washing or spray space.
  - Using breathe preventive facilities when weld shielded steel for it will cause poisonous dust and gas.

 **WARNING** The arc, spark, residue and noise are harmful to health, please wear protective appliance.

- Eye protection against arc is recommended when welding or supervise welding.
- Please wear preventive spectacles.
- Welder's gloves, welder's goggles, long sleeve clothes, leather apron, and other standard protection equipments must be worn for welding operation.
- A screen to protect other people against the arc must be set in the welding place.

 **WARNING** Please follow the notes below to avoid gas cylinder toppling over or broken.

- Use the gas cylinder correctly.
- Use the equipped or recommended gaseous regulator.
- Read the manual of gaseous regulator carefully before using it, and pay attention to the safety notes.
- Fix the gas cylinder with appropriate holder and other relative parts.
- Never put the cylinder under high temperature or sunshine environment.
- Keep your face away from the gas cylinder exit when opening it.
- Put on the gas shield when it is not used.
- Never put the torch on the gas cylinder. The electrode can not meet the gas cylinder.

 **WARNING** Any touch of the switch part will cause injury, please note the following.

- Never use the machine when the enclosure is off.
- Install, operate, check and maintain the machine by professional person.
- Keep your fingers, hair, clothes etc. away from the switch parts such as the fan.

 **WARNING** The wire end may deal damage, please note the following.

- Never look into the electric conduction hole when checking the wire feeding is normal or not, , or the shooting wire may stab your eyes and face.
- Keep your eyes, face or other naked parts away from the end of torch when feeding the wire manually or pressing the switch.

 **ATTENTION** For better work efficiency and power source maintenance, please note the following.

- Precautions against toppling over.
- Never use the welding equipment for pipe thawing.
- Lift the power source from side when use the up-down forklift truck to avoid toppling over.
- When using the crane for lift, tie the rope to the ears with an angle no more than  $\phi 15$  to the vertical direction.
- When lifting the welding machine which equipped with gas cylinder and wire feeder, download them from the power source and ensure the horizontal of the machine. Do fix the gas cylinder with belt or chain when moving it to avoid body hurt.
- Ensure fastness and insulation when lifting the wire feeder through the swing ring for welding.



**ATTENTION Electromagnetic interference needing attention.**

- It may need extra preventive measures when the equipment is used in particular location.
- Before the installation, please estimate the potential electromagnetism problems of the environment as follows.
  - a) Upper and lower parts of the welding equipments and other nearby power cable, control cable, signal cable and phone cable.
  - b) Wireless electric as well as TV radiation and reception equipment.
  - c) Computer and other control equipments.
  - d) Safety-recognition equipment etc. Such as supervise of industrial equipments.
  - e) Health of people around. Such as personnel using heart pacemaker or audiphone.
  - f) Equipments for adjustment and measurement.
  - g) Anti-disturb capability of other used equipments .Users should ensure these equipments and the environment are compatible, which may need extra preventive measures.
  - h) Practical state of the welding and other activities.
- Users should observe the following dos and don'ts to decrease radiation interference.
  - a) Connect the welding equipments to the power supply lines.
  - b) Maintain the welding equipments regularly.
  - c) The cable should be short enough to be close to each other and the ground.
  - d) Ensure the safety of all the welding metal parts and other parts nearby.
  - e) The workpiece should be well earth.
  - f) Shield or protect the other cable and equipments to decrease the effects of disturbances. The welding equipments can be complete shielded in some special conditions.
- Users are responsible for interference due to welding.



## 2 Product

### 2.1 General

The welding machine applies the most advanced inversion technology in the world.

The principle of inversion is to transform the power frequency of 50Hz/60Hz into direct current and invert it into high frequency through high-power device IGBT, then perform voltage-drop and commutation with the output high-power D.C power supply via Pulse Width Modulation (PWM). Since the switch power inversion technology is adopted, the weight and volume decrease greatly while the conversion efficiency increasing of more than 30%.

Additional to MIG, the machine has the functions of STICK and TIG, and the MIG function includes 100% CO<sub>2</sub> and mixed gas. The machine adopts full digital panel display, which can realize synergic adjustment of feeding speed and welding voltage as well to regulate the welding parameters easily.

Our CO<sub>2</sub> gas shielded welding machine is equipped with unique electronic reactor circuit, which can precisely control the short-circuiting transfer and mixed transfer resulted in better performance than other machines. Compared with silicon controlled welding machine and tapped welding, our products have the following advantages: stable wire feed rate, portable, energy-saving, electromagnetic noise free. Besides, our products spatter less, easier arc starting, deep welding pool, high duty cycle etc.

This equipment is portable with full function of STICK, TIG and plasma cutting having merits of high-efficiency; power-saving etc .It is especially suitable for family usage and need of different metal or techniques demand.

Thank you for choosing our products. Please feel free to propose your valuable suggestions; we will make efforts to perfect our products and service.



**The machine is mainly used in industrial fields. It will cause radion interference if used indoors. Please take through precaution measures.**

---

## 2.2 Technical data

Type	MIG 160GDM
Item	
Power voltage (V)	1 phase ~ 230V±15%
Frequency (Hz)	50/60
Rated input current (A)	28
Output current adjustment (A)	10-160 (MMA) 50-160 (MIG) 10-160 (TIG)
Output voltage (V)	20.4-26.4 (MMA) 16.5-22 (MIG) 10.4-16.4 (TIG)
No-load voltage(V)	64
Duty cycle (%) / 40°C	25 (MMA) 30 (MIG) 35 (TIG)
Power factor	0.73
Efficiency (%)	80
Type of wire feeder	Internal
Wire feeding speed (m/min)	3-12
Post flow time (S)	1
Wire diameter (mm)	0.8
Insulation grade	F
Housing protection grade	IP21
Welding thickness (mm)	2-10
Weight (kg)	8
Overall dimension L*W*H (mm)	386*170*300

<b>Type</b>	<b>MIG 180GDM</b>
<b>Item</b>	
Power voltage (V)	1 phase ~ 230V±15%
Frequency (Hz)	50/60
Rated input current (A)	28 (MMA) 27.4 (MIG) 20.5 (TIG)
Output current adjustment (A)	10-160 (MMA) 50-180 (MIG) 10-180 (TIG)
Output voltage (V)	20.4-26.4 (MMA) 16.5-23 (MIG) 10.4-17.2 (TIG)
No-load voltage (V)	64
Duty cycle (%)/ 40°C	25
Power factor	0.73
Efficiency (%)	80
Type of wire feeder	Internal
Wire feeding speed (m/min)	3-12
Post flow time (S)	1
Wire diameter (mm)	0.8
Insulation grade	F
Housing protection grade	IP21
Welding thickness (mm)	2-10
Weight (kg)	8
Overall dimension L*W*H (mm)	386*170*300

### 3 Installation

The welding equipment is equipped with power voltage compensation device. It keeps the machine work normally when power voltage fluctuating  $\pm 15\%$  of rated voltage.

When using long cable, in order to reduce voltage drop, big section cable is suggested. If the cable is too long, it will affect the performance of arcing and other system function, it is suggested to use the recommend length.

- Make sure the intake of the machine is not covered or blocked to avoid the malfunction of the cooling system.
- Use ground cable whose section no less than  $6\text{mm}^2$  to connect the housing and earth. The method is to connect the grounded interface in the back to the earth device, or make sure the earth end of power interface has been reliably and independently grounded. Both ways can be used together for better security.

#### Installation Procedures

##### ● Correct Installation of MIG

- a) Connect the gas cylinder with  $\text{CO}_2$  decompression flow meter tightly to  $\text{CO}_2$  mouth behind the machine via air tube.
- b) Insert the swift plug of earth cable into socket at the front panel.
- c) Set the wire wheel with wire on the wheel axis, the wheel hole should be matched with the wheel fixer.
- d) Choose wire slot according to wire size.
- e) Loosen the screw of wire-pressing wheel, pit the wire into slot via wire-lead tube, adjust the wire-pressing wheel to keep wire fix from gliding, but strength should be suitable in case the wire distorts and affects wire sending.
- f) Wire roll should turn clockwise rotation to let out wire, to prevent wire from gliding; wire is usually set to the fixed hole on the wheel side. To prevent the bent wire from getting stuck, please cut off this part of the wire.
- g) Put and tighten the torch on the output socket and put the wire into the torch by hand.

##### ● Correct Installation of TIG

- a) Connect the shielded-gas source correctly. The gas supplying route shall include gas cylinder, argon decompression flow meter and gas pipe. The connecting parts of the gas pipe should be fastened by hose clamp or other objects, in order to prevent leakage and air-in.
- b) Connect the plug of TIG torch to “-“ of the front panel, and fasten it clockwise.
- c) Connect the plug of TIG torch to the relative interfaces of panel and fasten the screw.
- d) Connect one end of the earth clamp cable to “+” of the front panel, and fasten it clockwise, the other end clamp the workpiece.

##### ● Correct Installation of STICK

- a) Make sure cable with electrode holder and quick plug connected well. Connect the quick plug to the socket “-“ of the machine, and fasten it clockwise tightly.
- b) Connect the quick plug at one end of the cable into the socket “+” of the machine, and

fasten it clockwise, the other end clamps the workpiece.

- c) Please pay attention to the connecting terminal, DC welding machine has two connecting ways: positive connection and negative connection. Positive connection: holder connects with “-” terminal, while work piece with the “+” terminal. Negative connection: work piece with the “-” terminal, holder with the “+” terminal. Choose suitable way according to the working situation. If unsuitable choice is made, it will cause unstable arc, more spatters and conglutination. If such problems occur, please change the polarity of the fastened plug. It should adopt negative connection when welding with alkaline electrode, while positive connection when welding with acid electrode.

**This procedure shall be operated by electrician!**

Connect proper power cable to the distribution box with corresponding capacity according to the input voltage and current (See technical parameter table). Do not connect to the inappropriate voltage and make sure that the difference of power supply is within permitted range.

**Installation diagram (MIG)**

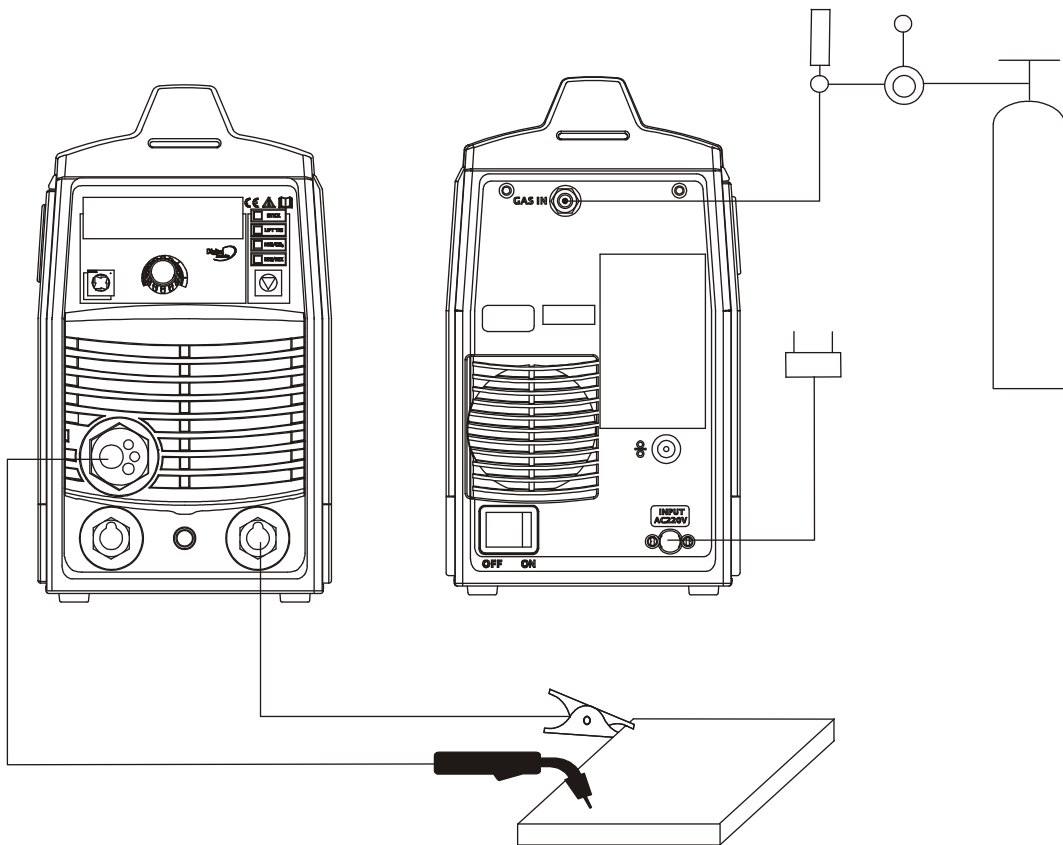

### Installation diagram (TIG)

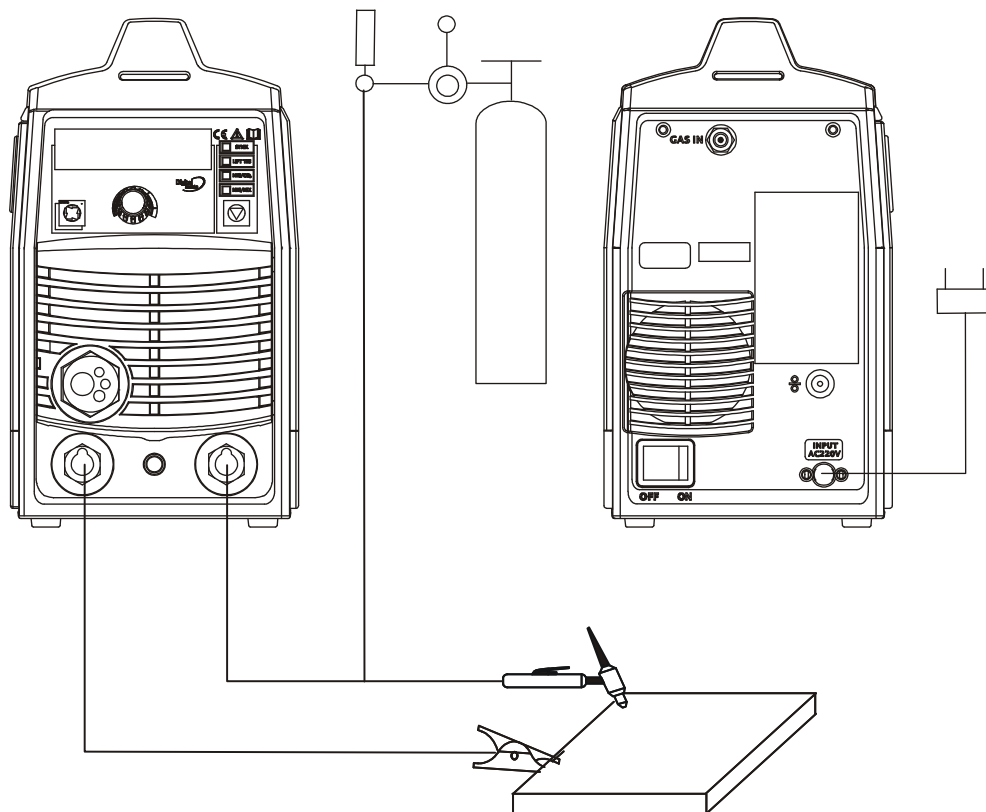

### Installation diagram (STICK)

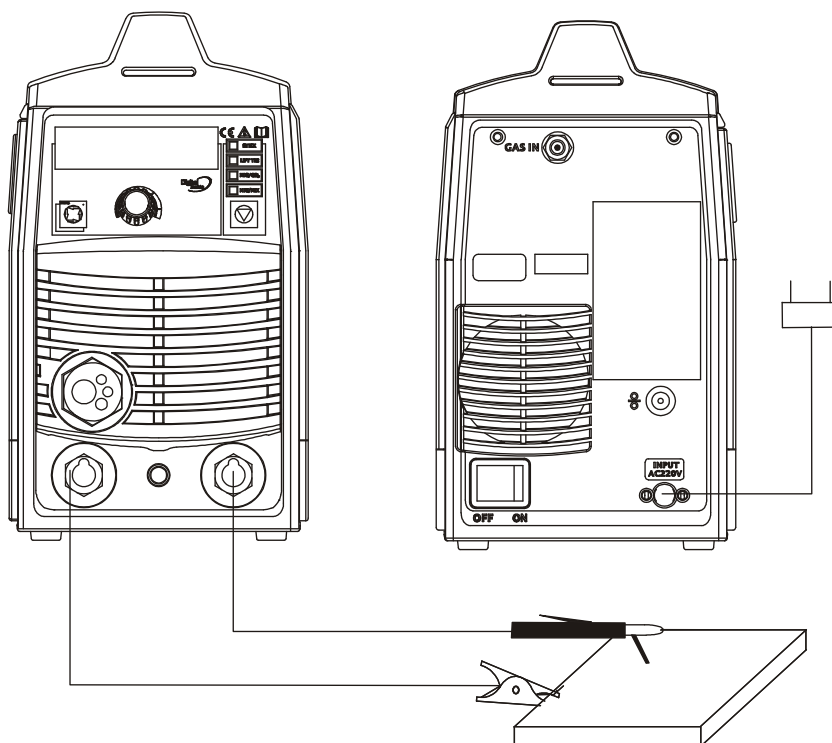

## 4 Operation

### 4.1 Front panel layout

- MIG 180GDM

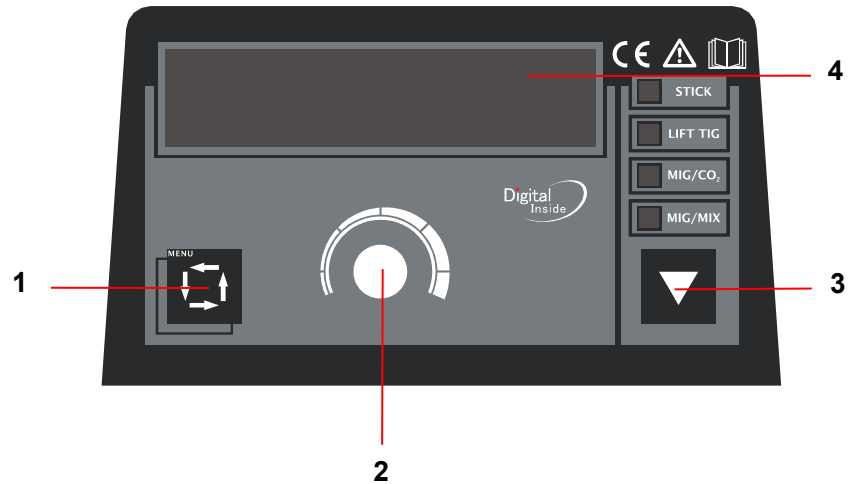

#### Front panel instruction.

1 - Data selection button

2 - Multifunctional data adjusting knob

Coarse adjustment by pressing and turning the knob.

Fine adjustment by turning the knob directly.

3 - Welding mode switch key.

Select the welding mode as MMA, TIG, MIG (CO<sub>2</sub>) and MIG (MIX).

4 - Multifunctional data display

### 4.2 Operation instruction

- **The starting up display**

Switch on the welding power source, the front panel displays as Fig. 1. After the 【Welding current display】 (or press any key or knob on front panel) flashes for 5 seconds, the machine enters into the welding mode that saved in the last shutdown.

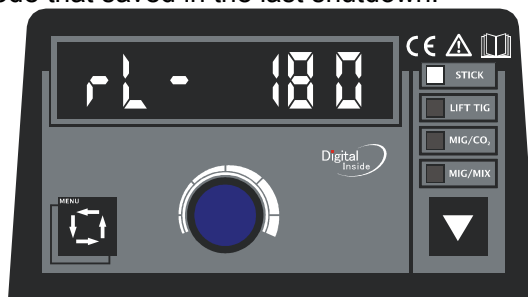
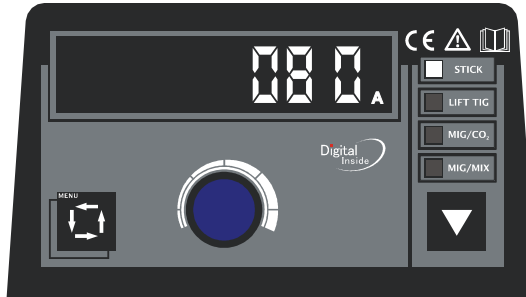

Fig. 1: the starting-up display interface

- **Operation instruction under STICK mode.**

- When welding stops, Press the **【Welding mode switch key】** , the STICK indicator lights up, and it turns into STICK mode.
- When under STICK mode, pressing the **【VRD/2T/4T switch key】** for 5 second to selection the VRD function, the function is enabled when the indicator lights up, and displays in **【multifunctional data display】**. Or, the VRD function is disabled when the indicator is off as shown in Fig. 2.

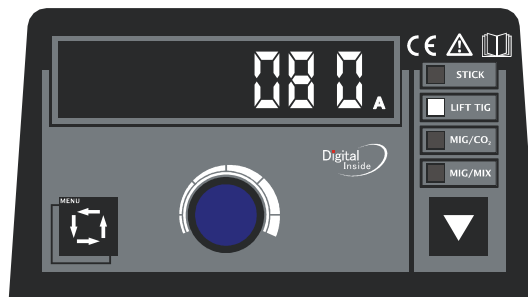

**Fig. 2 Preset current display with VRD enabled under STICK mode**

- 【Multifunctional data display】** shows the preset current“080A”, its unit is ampere(A).
- Adjusting the **【Multifunctional data adjusting knob】** can change the welding current during welding process, and displayed in **【Multifunctional data display】** .
- 3 seconds later after setting the welding parameters, the **【Multifunctional data display】** would flashes for one time, which means the data has been saved. Moreover, the panel would display these data when restart the machine next time if the parameters keep unchanged.
- When perform welding, the display shows the real time welding voltage and current. 5 seconds later, it returns to the preset current state.

- **Operation instruction under TIG mode.**

- When welding stops, press the **【Welding mode switch key】** , the TIG indicator lights up, and it turns into TIG mode.
- Under TIG mode, the multifunctional data display is as shown in Fig.3.



**Fig.3: The preset current under T TIG mode**

- 【multifunctional data display】** shows the preset current“080A”, its unit is ampere(A).
- Adjusting the **【Multifunctional data adjusting knob】** can change the welding current during welding process, and display in **【multifunctional data display】** .
- 3 seconds later after setting the welding parameters, the **【multifunctional data display】** would flashes for one time, which means the data has been saved.
- When perform welding, the display shows the real time welding voltage and current. 5 seconds later, it returns to the preset current state.

- **Operation instruction under MIG mode (both 100% CO<sub>2</sub> and mixed gas).**

- When welding stops, press **【Welding mode button】** , the welding machine turn into MIG mode and MIG indicator lights on.
- Under this mode, the **【Main display】** shows the preset voltage and preset wire speed as



Fig. 4.

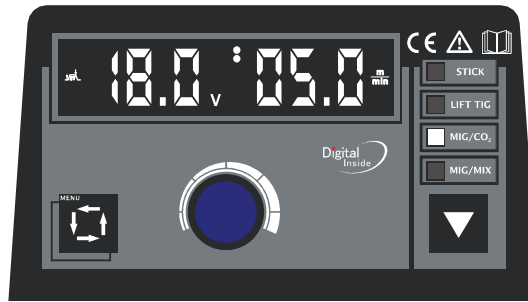

Fig. 4: Preset voltage display under MIG mode

- c) Press the **【Menu button】** for the 1st time, the **【Main display】** shows the fine adjusting range of preset welding voltage. Turn the **【Data adjusting knob】** to set the range from -20% to +20% as Fig.5.

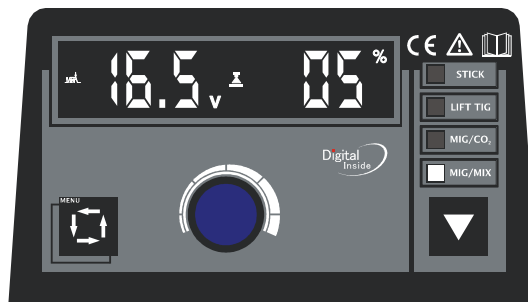

Fig. 5 Fine adjustment of preset range of voltage under MIG mode

- d) Press the **【Menu button】** for the 2nd time, the **【Main display】** shows the fine adjusting range of inductance. Turn the **【Data adjusting knob】** to set the range from -10% to +10% as Fig.6.

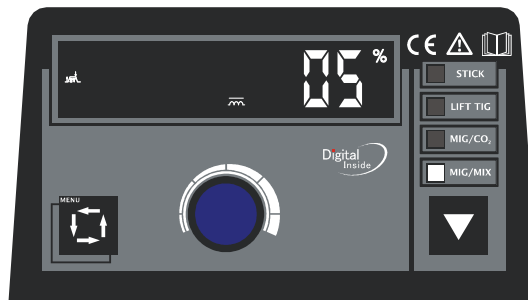

Fig.6 Fine adjustment of inductance range under MIG mode

- e) Press the switch of MIG gun. It starts wire inching. And the **【Main display】** shows as Fig. 7. When connected with MIG gun, press the torch switch for 5s without welding, the internal wire spool in the machine starts to rotate and wire feeding at a high speed 11m/min for 20s. Then it stops automatically. When release the button in 20s, wire feeding stops automatically.

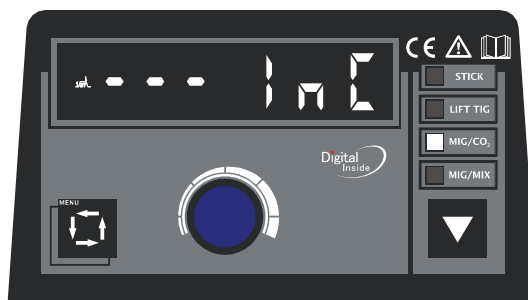

Fig. 7: Wire inching display under MIG mode

- f) The machine has the function of 2T/4T under MIG mode.  
 2T mode – press the **【Menu button】** for 5s, the function is on and the **【Main display】** shows “2T”. Press the torch switch, the machine starts welding, while release the switch, welding stops.  
 4T mode – Press the **【Menu button】** for 5s again, it turns into 4T mode and the **【Main display】** shows “4T”. Press the torch switch for 1st time, it goes into arc initiation current. Release the switch for 1st time, the machine starts welding. Press the switch for 2nd time, it goes into crater current. Release the switch for 2nd time, welding stops.
- g) Adjust **【Data adjusting knob】** during welding can realize the synergic manipulation of welding voltage and feeding speed, which displays in**【Main display】**. The adjustable range is 16.9V 3.3m/min to 23.3V 11m/min 17.5V under 100% CO<sub>2</sub> mode, 15.5V 3.3m/min to 19.5V 11m/min under mixed gas mode.
- h) When perform welding, the display shows the real time welding voltage and current. 5 seconds later, it returns to the preset welding voltage and wire speed.
- i) Release the torch switch, it stops welding. The Main display shows “HOLD” for 3 seconds. The **【Main display】** redispays welding voltage and wire speed.

- **Malfunction display of overheating protection**

The Multifunctional data display shows “-P- -EH-” and flashes continuously, the machine is not working normally now. Only when the temperature of the welding machine falls below 55°C, the overheating malfunction would disappear, and the machine works normally, no need restart up.

### 4.3 Welding environment and safety

- **Working surrounding**

- a) The machine works in environment where air conditions are dry with a dampness level of max 90%.
- b) Ambient temperature should be between -10 to 40 degrees centigrade.
- c) Avoid welding in sunshine or raining. Avoid water entering the machine
- d) Avoid welding in dust area or the environment with corrosive gas.
- e) Avoid gas welding in the environment with strong airflow.

- **Safety norms**

Our welding machine has a protection circuit of over voltage, over current and over heat. When voltage, output current and temperature of machine are exceeding the rated standard, welding machine will stop working automatically. Excessive operation under over voltage, over current or over heat may damage the machine; operator must pay attention to followings.

- a) The working area is adequately ventilated !

The welding machine is medium and small model. But the running of the machine will also generate high currents, which natural wind circulation cannot satisfy its cooling demands.

Therefore, each machine has an internal fan to ensure its stable performance. Make sure the intake is not blocked or covered, there should be 0.3 meter distance from welding machine to objects of environment. User should make sure the working area is adequately ventilated. It is important for the performance and the longevity of the machine.

b) Do not over load !

The operator should keep an eye on max duty current (Compared to the selected duty cycle) to make sure that the machine working current does not exceed max duty cycle current. Over-load current will damage and even burn the machine.

If machine exceeds standard duty cycle, it may stop working and switch to protection status. The temperature control switch is activated by over heat released under this circumstance. Meanwhile, the over heat indicator lights up. Under this situation, you do not need to pull out the power plug since the internal fan can work to cool down the machine. When the over heat indicator stops, the temperature has been lowed down to standard range, operator is able to starting working again.

c) No over voltage !

Power voltage can be found in diagram of parameters. Automatic compensation circuit of voltage will assure that welding current keeps is in allowable range. If power voltage is exceeding allowable range limits, it can damage the components of machine. The operator should understand this situation and take preventive measures.

d) There is a grounding cable behind welding machine with a mark. Before operation, welding crust must be grounded reliably with cable, in order to prevent static electricity, and accidents for electricity leaking.

#### 4.4 Welding problems and resolution

The phenomenon listed below may happen due to relevant accessories used, welding material, surroundings and power supply. Pleas improve surroundings and avoid these problems.

- **Arc starting difficulty. Arc interruption happens easily.**

- a) Examine whether grounding wire clamp contacts with the work pieces well.
- b) Examine whether each joint has improper contact.

- **The output current fails to reach rated value.**

The deviation of power voltage from rated value may cause that the output current does no accord with adjusted value. When the power voltage is lower than rated value, the maximum output current may be lower than rated value.

- **The current can not keep stable during operation.**

This situation may relate to the following factors:

- a) The voltage of electric power network changes;
- b) Serious interference from electric power network or other electric facilities.

- **Gas vent in welds.**

- a) Examine whether the gas supply circuit has leakage.
- b) Examine whether there is sundries such as oil, dirt, rust, paint etc. on the surface.

## 5 Daily maintenance and checking

- **Daily maintenance**

- a) Remove dust regularly with dry compressed air. If the welding machine is used in surroundings with heavy smoke and polluted air, it is necessary to remove dust at least one time one month.
- b) The pressure of compressed air shall fall to required level to prevent damage to small components in the machine.
- c) Examine inside electric joints and ensure perfect contact (Especially plugs and sockets). Fasten the loosing joints. In case of oxidation, remove oxide film with sand paper and connect again.
- d) Prevent water from entering into the machine and prevent the machine from getting moist. If any, blow and dry. Measure the insulation with megohmmeter to make sure it is qualified to use.
- e) If the welding machine is not used for a long time, pack the machine in original package and store in dry surroundings.
- f) Every time the wire feeder operates for 300hours, grind the electrical carbon brush and clear up the armature commutator. Rinse speed reducer, apply 2# Molybdenum Disulfide lubricant to the turbine, whirlpool rod and bearing.



**All the maintenance and testing must be carried out when the power supply is totally cut off. Please make sure the power is off before opening the closure.**

---

- **Daily checking**

<b>WELDING POWER SUPPLY</b>		
<b>Position</b>	<b>Check points</b>	<b>Remarks</b>
Control panel	1. Switch condition of operation, transfer and installation 2. Test the power indicator	
Cooling fan	1. Check if there is wind and the sound normal or not	If abnormal noise and no wind, please check the inner
Power part	3. When electrified, abnormal smell or not 4. When electrified, abnormal vibration and buzz or not 5. Color changing and heating or not in appearance	
Periphery	6. Gas pipe broken, loosen or not 7. Housing and other fixed parts loosen or not	

<b>WELDING TORCH</b>		
<b>Position</b>	<b>Check points</b>	<b>Remarks</b>
Nozzle	If installation fixed, the front distorted	Reason for air hole
	Attach splash or not	Reason for burning the torch (can use splash-proof material)
Electric hole	If installation fixed	Reason of torch screw thread damage
	Damage of its head and hole blocked or not	Reason of unstable arc and broken arc
Wire sending tube	Check the extended size of the pipe	Change when less than 6mm, when the extended part too small, the arc will be unstable
	Wire diameter and the tube inner diameter match or not	Reason of unstable arc, please use the suitable tube
	Partial bending and extended	Reason of poor wires sending and unstable arc, please change
	Block caused by dirt in the tube, and the remains of the wire plating lay	Reason of poor wire sending and unstable arc, (use kerosene to wipe or change new one)
	Wire sending tube broken	Pyrocondensation tube broken, change new tube
Gas bypass	Forget to insert or the hole blocked, or different factory component	May lead to vice (splash) because of poor gas shield, torch body get burned (arc in the torch), please handle

<b>WIRE SENDING MACHINE</b>		
<b>Position</b>	<b>Checking keys</b>	<b>Remarks</b>
Pressing arm	If put the arm to the suitable indicating level	Lead to unstable arc and wire sending
Wire lead tube	If powder or residue store up in the mouth of the tube	Clean the residue and check the reason and solve it
	Wire diameter and the tube inner diameter match or not	If not match, lead to unstable arc and residue
	If the tube mouth center matches the wire wheel slot center or not. (Eyeballing)	If unmatched, lead to unstable arc and residue
Wire wheel	Wire diameter matches the wheel's requirement If the wheel slot blocked	1. Lead to unstable arc and residue, and block wire tube 2. Change new one if necessary
Pressure wheel	Check the stability of its move, and wearing-out of pressed wire, the narrowing of its contact surface	Lead to unstable arc and wire sending

<b>CABLE</b>		
<b>Position</b>	<b>Checking keys</b>	<b>Remarks</b>
Torch cable	1. If torch cable over bended 2. If the metal connecting point of mobile plug loosen	1. Cause poor wire sending 2. Unstable arc if cable over bended
Output cable	1. Wearing-out of the cable insulated material 2. Cable connecting head naked (insulation damage), or loosen (the end of power supply, and cable of main material connecting point)	For life security and stable welding, adopt suitable method to check according to working place ● Simple check daily ● Careful and in-depth check on fixed period
Input cable	1. If the connection between the plug and the power socket is firm 2. If the power input end cable fixed 3. If the input cable is worn out and bares the conductor	
Earth cable	If the earth cable that connects the main part is broken and connects tightly	

## 6 Trouble shooting and fault finding

**Notes:** The following operations must be performed by qualified electricians with valid certifications. Before maintenance, you are suggested to contact local distributor to verify qualification.

Malfunctions	Solution
<p>The meter shows nothing; Fan does not rotate; No welding output</p>	<ul style="list-style-type: none"> <li>➤ Confirm the power switch is on.</li> <li>➤ Power supply available for input cable.</li> <li>➤ Check if the silicon bridge is damaged.</li> <li>➤ There is malfunction occurs in the supplementary power source on control board (contact dealers).</li> </ul>
<p>The meter shows; Fan works normally; No welding output</p>	<ul style="list-style-type: none"> <li>➤ Check if all the sockets in the machine are connected well.</li> <li>➤ There is open circuit or badness of connect at the joint of output terminal.</li> <li>➤ The control cable on the torch is broken off or the switch is damaged.</li> <li>➤ The control circuit is damaged.(contact to dealers)</li> </ul>
<p>The meter shows; Fan works normally; Abnormal indicator lights.</p>	<ul style="list-style-type: none"> <li>➤ It might be over-current protection, please turn off the power switch; restart the machine after the abnormal indicator light winked.</li> <li>➤ It might be overheating protection, please wait for about 2-3 minutes until the machine renew without turn off the power switch.</li> <li>➤ It might be multifunction of inverter circuit. (contact dealers)</li> </ul>

## Appendix I Welding parameter list

Please refer to the following parameter in operation.

- **Generally, welding current is adequate to welding electrode according with as following.**

Electrode specification	φ2.5	φ3.2	φ4.0	φ5.0
welding current	70-100A	110-140A	170-220A	230-280A

- **Welding variables when use TIG.**

TIG welding specifications of stainless steel as follows

Thickness(mm)	Tungsten diameter (mm)	Wire diameter(mm)	Type of butt joint	Welding current(A)	Gas flow(L/min)
0.5	1.0	1.0	plain butt joint	35-40	4-6
0.8	1.0	1.0	wire filling	35-45	4-6
1.0	1.6	1.6		40-70	5-8
1.5	1.6	1.6		50-85	6-8
2.0	2.0-2.5	2.0		80-130	8-10
3.0	2.5-3.0	2.25		120-150	10-12



# Appendix II Circuit diagram

